

# High Temperature

## Insulation Textiles & Accessories for Industry

Felts & Blankets



Treated Fabrics



Accessories



Threads



Hogrings



# EWCO

Specialty Products, Inc.

High Temperature Insulation Textiles

ISO 9001-2000 Certified

# High Temperature Felts & Blankets

## E Glass Felts & Blankets

Lewco E Glass Felts and Blankets are composed of 100% select-grade type “E” glass fibers needled together into blanket form. It is INCOMBUSTIBLE, ASBESTOS-FREE and contains NO RESINOUS OR INORGANIC BINDERS. Lewco Glass Mat can be used on equipment operating at temperatures to 1200°F and will not deteriorate or shake apart in vibrating applications. Conforms to Mil. Spec. Mil-I-16411, Mil-I-24244, ASTM E-84. Smoke -O, Flame -O NRC-1.36.

## Silica Felts & Blankets

Lewco Sil Felts and Blankets insulation is manufactured using 98% pure textile grade silica fiber needled together into blanket/felt form. Lewco Sil blanket base fiber is made through a hot extrusion process yielding a 6-11 micron, non-respirable fiber. This fiber is then processed to maximize thermal efficiency. Lewco Sil Mat is INCOMBUSTIBLE, ASBESTOS FREE, NON-RESPIRABLE, and contains no INORGANIC or RESINOUS BINDERS. Typical applications include engine exhaust system insulation, hot industrial equipment insulation, and many others. Maximum continuous temperature is 1800°F.

## Silica/Fiberglass Composite Blankets

Lewco can combine our Silica and Fiberglass insulation felts into needled composites that for many insulation applications can give customers the pricing advantage of Fiberglass with the high temperature properties of Silica fiber. Lewco can combine these two different felts into various thickness combinations to meet customer requirements. These insulation felt and blanket composites are strong enough to give long life in tough, difficult applications. Applications include Stress Relief blankets, Removable/Reusable Insulation for high noise level, high maintenance, high vibration and high temperature equipment or engine exhaust systems.

## Ceramic Fiber Products/Blankets

Lewco Refractory Ceramic Fiber products have two temperature grades – 2300°F and 2610°F. Lewco Ceramic Fiber Products feature a broad family of products that include Bulk Fiber, Needle Felted Blanket, Paper and Textiles. The products are ideal for High Temperature furnaces, filtration, gasket applications, stress relieving and other refractory applications.

48"	60"	1/8"
		1/4"
24"	30"	1/2"
		1"
		1-1/2"
		2"

## Typical Properties

	Silica	Fiberglass	Ceramic Fiber
Melting Point	3000°F	1523°F	3200°F
Maximum Continuous Operating Temperature	1800°F	1200°F	2150°F
Shrinkage	<7% (Continuous 1800°F)	_____	_____
Thickness	1/4", 1/2" & 1"	1/8- 1-1/2"	1/2", 1", 1-1/2", 2"
Roll Width	60"	30" & 60"	24" & 48"
Roll Length	Various Lengths Available	Various Lengths Available	Various Lengths Available
Density	1/4" - 8 lbs/cu.ft. 1/2" - 9 lbs/cu.ft. 1" - 10 lbs/cu.ft.	6-12 lb /cu.ft	6, 8 lb/cu.ft

## Thermal Conductivity (K-Factor) BTU, in./ft2, HR. °F

Temp °F	E-Glass 6# Density	E-Glass 10# Density	Silica 10# Density	RG 2300 8# Density
300	0.292	0.350		
500	0.350	0.480		
700	0.445	0.640		0.530
900		0.780	0.855	0.700
1200			1.115	1.000
1500			1.425	1.320
1800			1.820	1.780



# High Temperature Fabrics

## Silicone Coated/Impregnated Fiberglass Fabrics

Silicone Coated/Impregnated Fiberglass Fabrics excel in High Temp. Applications. Silicone adds abrasion resistance and water proofing to the fabrics. These fabrics are good for making insulation jacketing. Max. continuous temp. to 500°F.

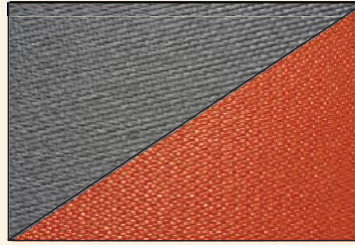

Style	Wt. (oz/yd <sup>2</sup> )	Width
1500SA-2	15.0	40", 60"
1700SA-2L	16.5	40", 60"
1700SA-2	17.0	40", 60"
1750SA-2	17.5	40", 60"
2000SA-2	20.0	40", 60"
3000SA-2	34.0	40", 60"
3700SA-2	37.0	40", 60"

## PTFE Coated/Laminated Fiberglass Fabrics

PTFE Coated fiberglass fabrics/films are very good high temp. hostile chemical-resistant fabrics. PTFE is inert against most acids and bases. Other PTFE laminates and film are available upon request. Continuous Temp. Max 550-600°F.

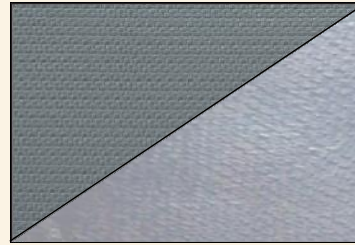

Style	Wt. (oz/yd <sup>2</sup> )	Width
1400T	14	60"
1650T	16.5	60"
1800T	18	60"
3400T	34	60"
1300T-Lew	13	60"
1800T-Lew	18	60"

## Texturized/Untexturized Fiberglass Fabrics

Type E Grade Fiberglass makes an ideal, cost-effective fabric for normal use to 1000°F. Bulk texturizing is very good to increase thickness for insulation applications. Vermiculite & HT Carmelizing available.



Style	Wt. (oz/yd <sup>2</sup> )	Width
300	8.5	60"
1800 F	17.5	40", 60"
2400F	24.0	40", 60"
3000F	30.0	40", 60"
3500F	35.0	40", 60"
4000F	40.0	40", 60"
6000F	60.0	40", 60"

## Lewco Silica Fabrics

High purity, non-respirable Silica Yarn is used to make a good, cost-effective fabric. A special vermiculite, weave-set coating is applied to help fabricators during the cut and sew process. Useful tensile strength to 1800°F. Melt Point: 3000°F.



Style	Wt. (oz/yd <sup>2</sup> )	Width
1800HTO	18	36", 60"
3600HTO	36	36", 60"
1800HTP	18	36", 60"
3600HTP	36	36", 60"

## Aluminized Fiberglass Fabrics

Aluminum Foil and Film laminated to Fiberglass Fabric creates an excellent vapor barrier against moisture or other fluids. Max. continuous temp. to 450°F.

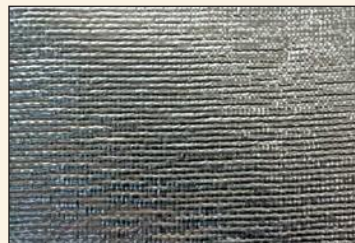

Style	Wt. (oz/yd <sup>2</sup> )	Width
2025-9480	21	60"
4011-4ply	22	60"

## Stainless Knitted Blanket Mesh & Foil

Blanket mesh should be a consideration in Removable/Reusable Insulation applications above 500°F. Blanket Mesh is a very flexible, circular knitted web made from a variety of grades of 0.008", 0.0095", 0.011" SS wire.



Type	Wire Diam.	Width
304 SS	.008"	24", 30", 42"
	.0095"	24", 30", 42"
	.011"	24", 30", 42"
Inconel®	.008", .011"	30"
Monel®	.008", .011"	30"
304 SS Foil	.002", .003"	24", 36"

## Acoustical Barriers

Lewco's acoustical noise barriers are flexible, tough, high-density, vinyl films possessing high tensile and tear resistance. Those products must be positioned so to keep the temperature exposure below 180°F.



Style	Wt. (lb./ft <sup>2</sup> )	Thk.
227	1/2 lb./ft <sup>2</sup>	0.45"
341	3/4 lb./ft <sup>2</sup>	0.70"
454	1 lb./ft <sup>2</sup>	0.90"
681	1 1/2 lb./ft <sup>2</sup>	0.124"

# Fabrication Accessories

## Sewing Threads and Drawcords

Lewco stocks a variety of high temperature, chemical-resistant Threads and Drawcords. Nomex®, Kevlar®, Fiberglass, Quartz and Stainless Steel Threads and Drawcords. Please contact Lewco for more information.



## Hoggrings and Tools

Lewco stocks the Spenax Pneumatic & hand-operated Hogring tools & Stainless and Galvanized staples. Lewco also offers a tool repair service for insulation customers. Please contact Lewco for more information.



## Fastening, I.D.'s and Accessories

Lewco maintains a good inventory of Belting, Buckles, Lacing Anchors, Quilting Pins, ID Tags and other materials that help complete the fabricated system.



## Threads

Sewing Threads	Styles	Thickness	Brk. Strn.	Temp	Yield
TEFLON Coated Fiberglass - Specially coated for excellent chemical and UV resistance. "L" suffix denotes an E-Z Sew finish has been added.	TCFT 18	.017"	19 lb.	750°F	2500 yds/lb.
	TCFT 18L	.017"	19 lb.	750°F	2150 yds/lb.
	TCFT 21	.021"	27 lb.	750°F	1875 yds/lb.
	TCFT 21L	.021"	27 lb.	750°F	1612 yds/lb.
Starch Coated Fiberglass - Specially coated to meet NRC requirements.	B8	.020"	31.3 lb.	750°F	1875 yds/lb.
Natural Kevlar®	T-90	.016"	16 lb.	380°F	4704 yds/lb.
Nomex®	T-70	.014"	4.5 lb.	480°F	6340 yds/lb.
Quartz®	Q-18	.017"	24 lb.	1500°F	1950 yds/lb.
Polyester/Inconel®	PINC	.0145"	8 lb.	1800°F	6500 yds/lb.
Kevlar®/10-Strand Stainless Steel	KSS 10-1	.012"	23 lb.	1500°F	2,264 yds/lb.
Kevlar®/5-Strand Stainless Steel	KSS 5-1	.011"	23 lb.	1500°F	3,456 yds/lb.
Kevlar®/3-Strand Stainless Steel	KSS 110	.011"	27 lb.	1500°F	4,141 yds/lb.

## Tools

Model	Staple Size	Staple Capacity	Staple Diameter	Min. Ring I.D.	Operating Pressure	Tool Weight
SC761	½"	100	16 Gauge, .062	¼"	80-100 PSI	3.87 lb.
SC743	¾"	110	16 Gauge, .062	⅜"	80-100 PSI	3.87 lb.
P7	½"	25	16 Gauge, .062	¼"	N/A	0.90 lb.

## Hoggrings

Hog Ring Part #	Hog Ring Tool	Quantity Per Box	Material	Diameter	Size	Diameter
12SS100	SC761	10,000	304SS	.062"	½"	¼"
34SS110	SC743	11,000	304SS	.062"	¾"	⅜"
SR8-G	P7	2,500	Galvanized	.062"	½"	¼"
SR8-SS	P7	2,500	304SS	.062"	½"	¼"

## Accessories

Products	Styles	Sizes	Material	Put-Up
Belting	1 & 1-½" Poly	1 & 1-½" x ⅛"	Poly	100 yd/roll
Buckles	1 & ½" D & Rec.	.125" x 1" & 1-½"	304SS	Ea.
VELCRO® brand fasteners	800-1", 1-½", 2"	1", 1-½", 2"	Nylon	50 yd/roll
Lacing	LASS & LAMS	12ga. & 14ga. 2-½" & 4-½"	304 SS/Mild	1000/Box
Quilting Pins	QPSS & QPMS	12ga. & 14ga. 2-½" & 4-½"	304SS/Mild	1000/Box
Retaining Clips	K150SS & K150G	12ga. & 14ga.	304SS/Galvanized	1000/Box
Two-Hole Washers	THW	1"	304SS	1000/Box
Tie Wire	Tie Wire	.051" & 0.47"	304SS	5 lb. & 25 lb.
I.D. Tags	I.D. Tag	1-½" x 3-½"	304SS	Ea.
Grommets	Grommet	Multiple available	Brass, 304 SS	Ea.
Drawcord	TCFR	⅜"	Teflon CTD FG	650'/spl
Drawcord	SSD	⅜"	304 SS	500'/spl



# Technical Information

## Cold Face Fabrics

- |   |               |
|---|---------------|
| 1. Silicone Impregnated Fiberglass & Silica | 500°F         |
| 2. PTFE/Teflon® Impregnated Fiberglass      | 550°F         |
| 3. Alum Foil/Film Laminated Fiberglass      | 450°F         |
| 4. Plain & Texturized Fiberglass            | 1,000°F       |
| 5. Stainless Steel Knitted Blanket Mesh     | 1,500-2,000°F |

## Hot Face Fabrics

- |  |         |
|--|---------|
| 1. Silicone Coated/Impregnated Fiberglass & Silica | 500°F   |
| 2. PTFE/Teflon® Impregnated Fiberglass             | 550°F   |
| 3. Alum Foil/Film Laminated Fiberglass             | 750°F   |
| 4. Plain & Texturized Fiberglass                   | 1,000°F |
| 5. Vermiculite Coated Fiberglass                   | 1,000°F |
| 6. Vermiculite Coated Silica                       | 1,800°F |
| 7. 304 SS Foil                                     | 1,500°F |
| 8. Inconel® Foil                                   | 2,000°F |
| 9. 304 SS Blanket Mesh                             | 1,500°F |
| 10. Inconel Blanket Mesh                           | 2,000°F |

## Blanket Insulation

- |   |         |
|---|---------|
| 1. Foams (Flexible, Closed Cell Elastometric) | 300°F   |
| 2. Needled E Glass Blanket                    | 1,200°F |
| 3. Needled E Glass/Silica Composite Blanket   | 1,500°F |
| 4. Needled Silica Blanket                     | 1,800°F |
| 5. Ceramic Fiber Blanket-RG                   | 2,400°F |
| 6. Ceramic Fiber Blanket-HTZ                  | 2,700°F |

## Threads

- |                              |         |
|------------------------------|---------|
| 1. Nomex®                    | 400°F   |
| 2. Kevlar®                   | 400°F   |
| 3. Plain Fiberglass          | 750°F   |
| 4. Teflon® Coated Fiberglass | 1,500°F |
| 5. Teflon® Coated Quartz     | 1,500°F |
| 6. Stainless Steel           | 1,500°F |
| 7. Inconel                   | 2,000°F |

## Hog rings and Staples

- |                    |         |
|--------------------|---------|
| 1. Galvanized      | 1,000°F |
| 2. Stainless Steel | 1,500°F |
| 3. Inconel®        | 2,000°F |

## Accessories

- |                            |                  |                       |
|----------------------------|------------------|-----------------------|
| 1. Belting                 | 5. Quilting Pins | 9. Grommets           |
| 2. Buckles                 | 6. Draw Cord     | 10. Two-Hole Washers  |
| 3. VELCRO® brand fasteners | 7. Tie Wire      | 11. Zinc, SS, O Rings |
| 4. Lacing Hooks            | 8. SS I.D. Tags  |                       |

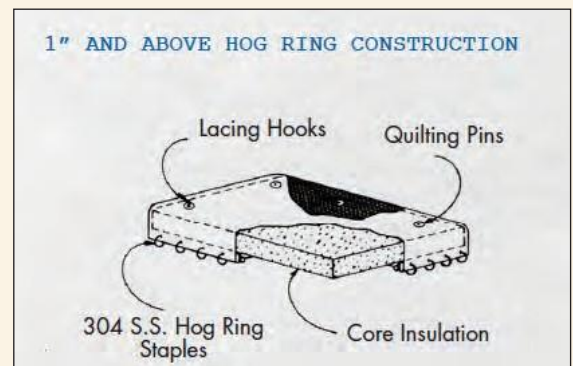
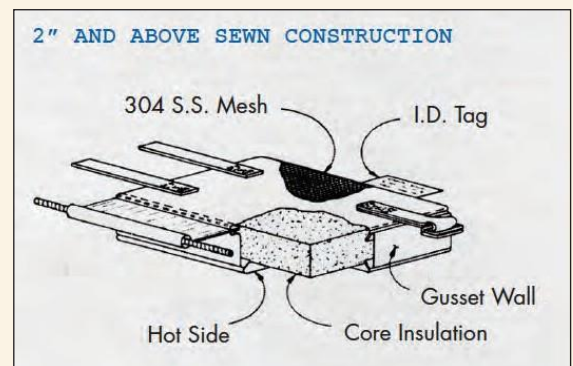
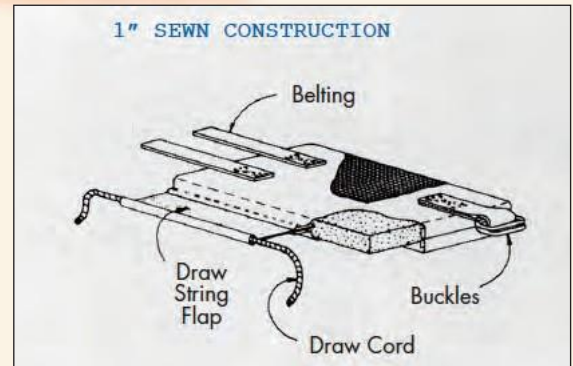

## Energy Audit

How much can you save  
using Removable /  
Reusable Insulation?

Calculate your losses at:  
<http://www.insulation.org/>

## Fabrication Training

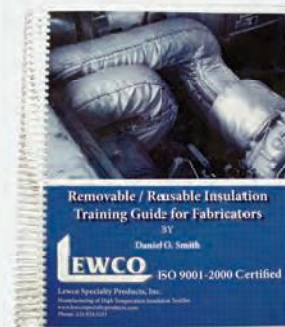

Lewco has 25 years experience making materials for Removable/Reusable insulation jackets. Please contact us for more information on our proven fabrication training system and training manual.

# Other Lewco Products



**Fabrics for Hot Works Safety**



**Ceramic Fiber Products**

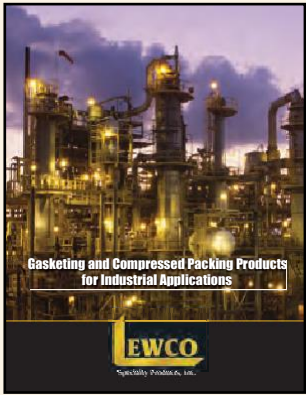

**Gasketing and Packing Products**

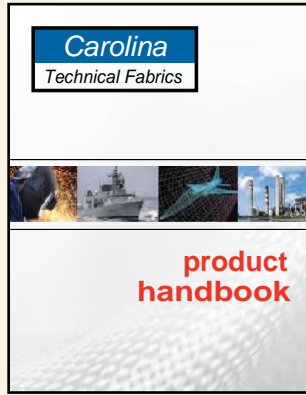

**Woven and Coated Fabrics**

# ISO 9001-2000 Certified

We will strive to meet or exceed our Customers' expectations. Lewco is committed to continually improving our products, services and the effectiveness of the Quality Management System to make our Customers totally satisfied.

*We believe our products and services must be...*

- **PRODUCED SAFELY**  
Our products and services are produced safely and in a safe work environment.
- **HIGH QUALITY**  
Our Service is courteous and professional. Our Products are manufactured under a Quality Management System certified as conforming to requirements defined in the ISO 9001:2000 Standard.
- **COMPETITIVE**  
Our products and services provide exceptional value for our Customers.
- **DELIVERED ON TIME**  
An inventory of finished products is maintained to meet our Customers' delivery requirements.
- **CONTINUALLY IMPROVED**  
We will work together to continually improve all aspects of our business.



Proud Member of  
**NIA**  
 National Insulation Association  
[www.insulation.org](http://www.insulation.org)  
 Since 1989

Member  
 SWICA  
 WIA  
 ESICA  
 SEICA  
 MICA  
 CSICA



All Major Credit Cards Accepted



Corporate Headquarters / Manufacturing & Distribution Center  
 6859 Renoir Avenue • Baton Rouge, Louisiana 70806  
 Phone (225) 924-3221 • Toll Free 1(800) 221-6414 • Fax (225) 927-2918  
[www.LewcoSpecialtyProducts.com](http://www.LewcoSpecialtyProducts.com) • Email [Lewco@LewcoSpecialtyProducts.com](mailto:Lewco@LewcoSpecialtyProducts.com)

Stocking Locations: Baton Rouge, LA • Houston, TX • Ontario, CA • Portland, OR • Columbia, SC